

CONNECT - NITOS: Methods and measurement tools for experimentation on wireless testbeds



Thanasis Korakis

CERTH / NITLab

University of Thessaly/ Department of Computer and Communication Engineering



CONNECT project

- It proposes a holistic network design approach that drastically enhances performance in wireless networks by unlocking the hidden potential of the broadcast wireless medium.
- Design and optimize cross layer, cooperative networks mechanisms from the PHY up to the application layer.
- Implementation of the proposed schemes in NITOS (UTH) and Openair Interface (EURECOM) testbeds
- NITOS testbed of University of Thessaly is used to implement and evaluate packet level cooperation schemes from the MAC to the application layer.
- Main focus on video aware cooperative networks schemes

NITOS Testbed

- Currently NITOS maintains
 - 50 Wi-Fi Nodes
 - 6 of them are equipped with GNU radios
 - All of them are equipped with temperature, humidity, photo sensors and cameras
 - 5 mobile nodes

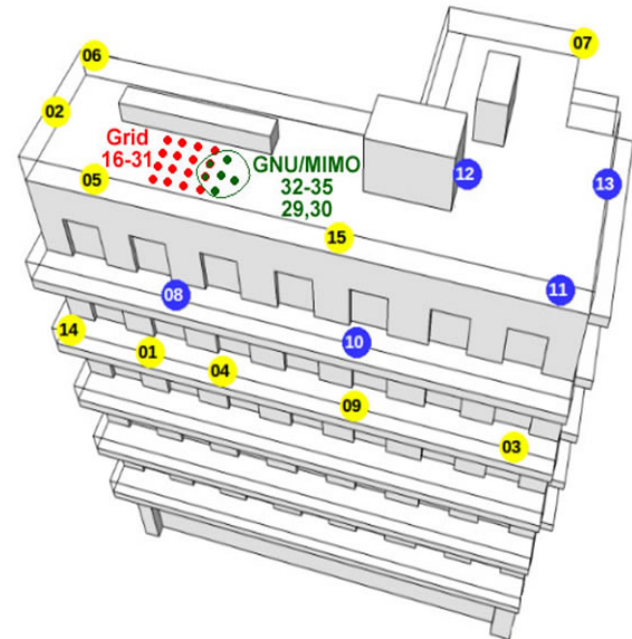

NITOS Extensions

- Up to 100 WiFi nodes
 - Extension of the outdoor testbed
 - Development of an indoor(isolated) testbed
- Addition of an LTE and 3G testbed for testing with real users
- Development of a vehicular testbed (WiFi/LTE/3G)
 - Cars/Taxis
 - Trains
 - Bicycles (in campus outdoor vehicular testbed)

NITOS Architecture

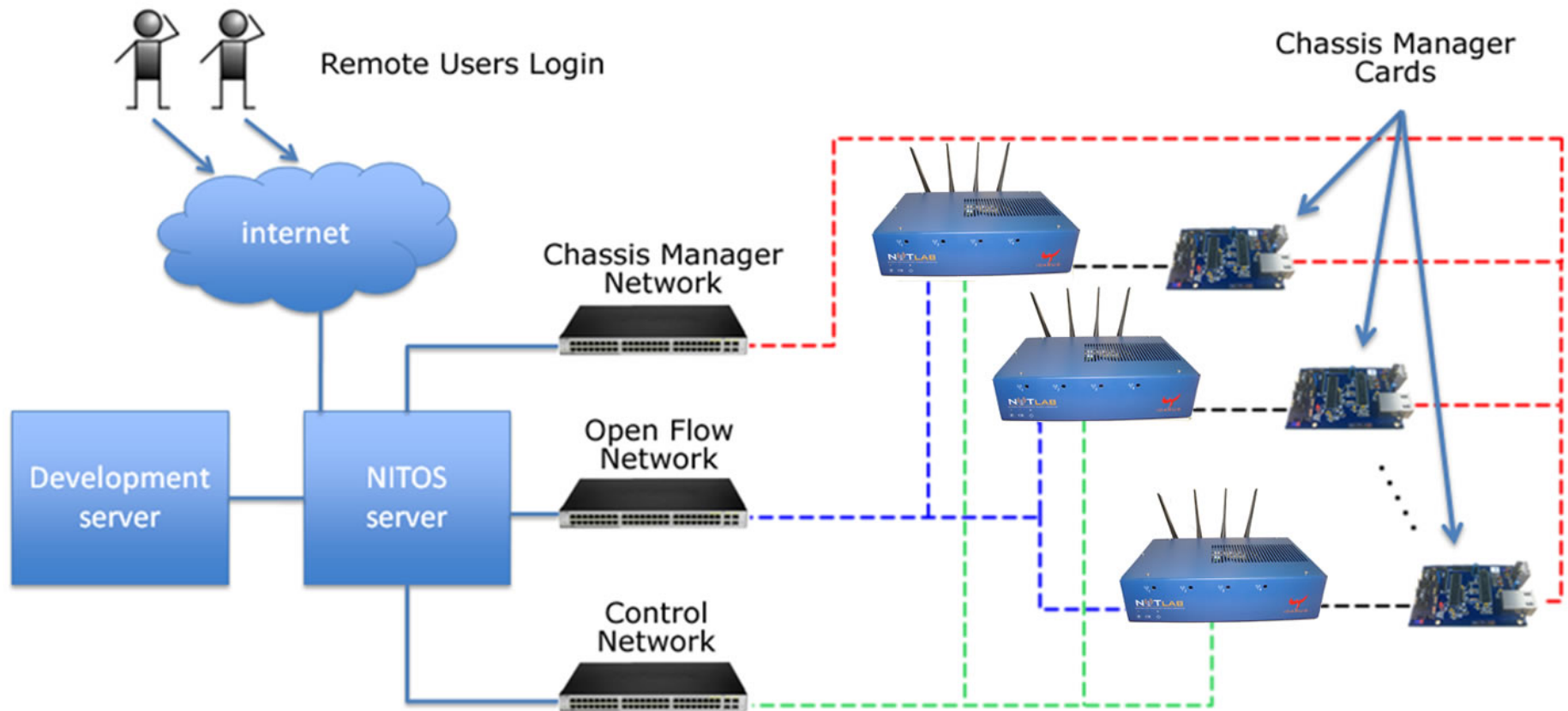

ICARUS Nodes

We have designed and developed new powerful WiFi nodes called ICARUS:

- Linux based
- Two WiFi cards with open source drivers
- Support of MIMO wireless cards



GNU Radios



6 of NITOS nodes are connected with GNU Radio boards

- NITOS provides a Framework that supports:
 - Physical and MAC layer implementation
 - Subcarrier allocation
 - Power control

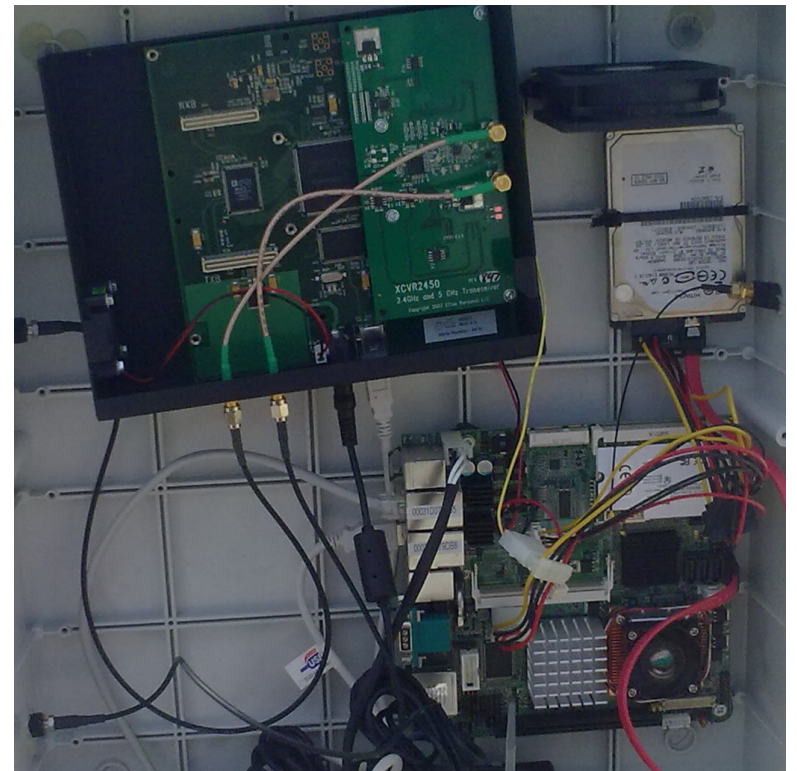

MIMO Framework



All MIMO-enabled nodes of NITOS are currently equipped with an extra box that has 3 Dual Band 2.4/5GHz, 5dbi Antennas mounted. The antenna box is also able to turn, so that the experimenter can create more specific topologies by exploiting the polarization of the antennas.

Chassis Manager Cards

- We have developed a Chassis Manager Card that is used to control the operation of wireless nodes (turn on/off the nodes remotely though http requests sent directly to the Ethernet port)

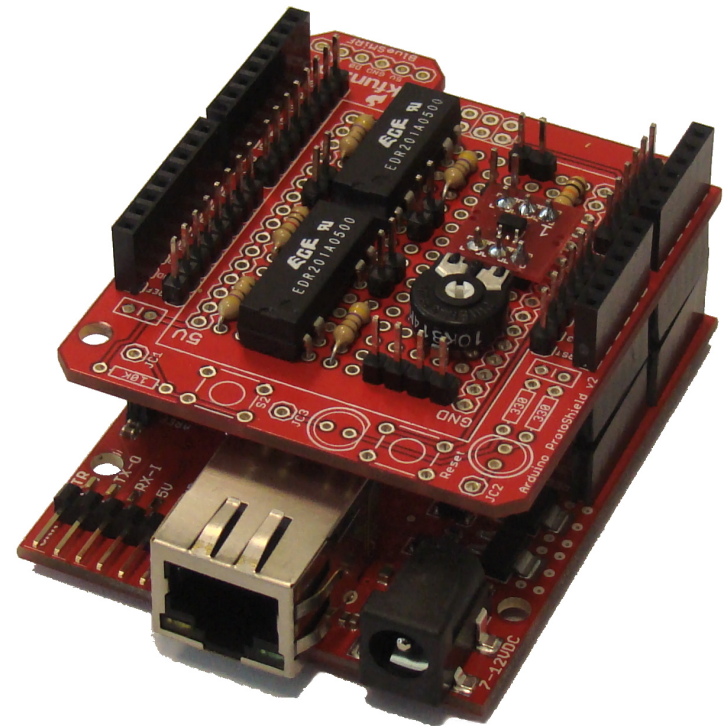
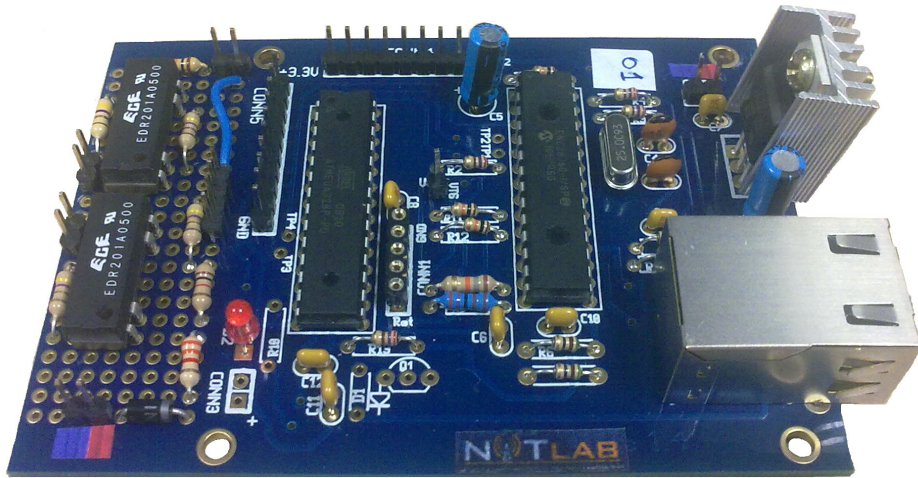

Chassis Manager Card's Sensors

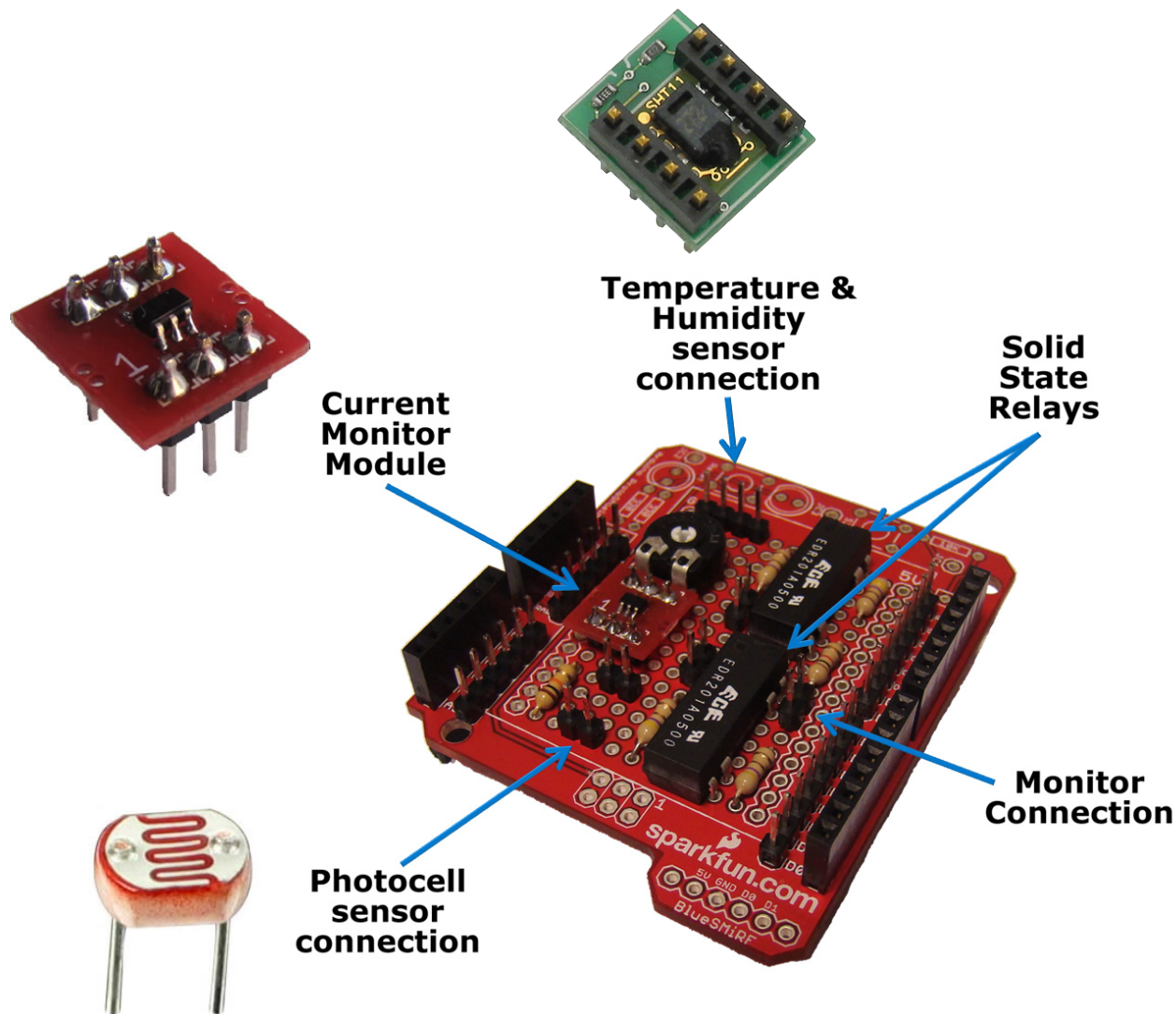

- Chassis Manager Cards features multiple type of sensors that can be controlled remotely

Mobile Nodes

- We have 5 mobile nodes in NITOS testbed equipped with:
 - Two WiFi cards
 - Cameras
 - Sensors
- The nodes can be controlled remotely by an internet based GUI
- The mobile nodes can collect sensors measurements while it moves around



OMF

- OMF stands for: **c**ontrol and **M**anagement **F**ramework
- It is a software framework dedicated to:
 - The efficient management of testbed resources by the testbed administrators
 - Providing a clear and easy way for an experimenter to define an experiment, execute it and collect its results
- Initially developed at Winlab, Rutgers to run the ORBIT wireless testbed
- Currently, NICTA (Sydney) is responsible for maintaining and further developing OMF, with help and contributions from others (Winlab, Nitlab, ...)

OMF Overview

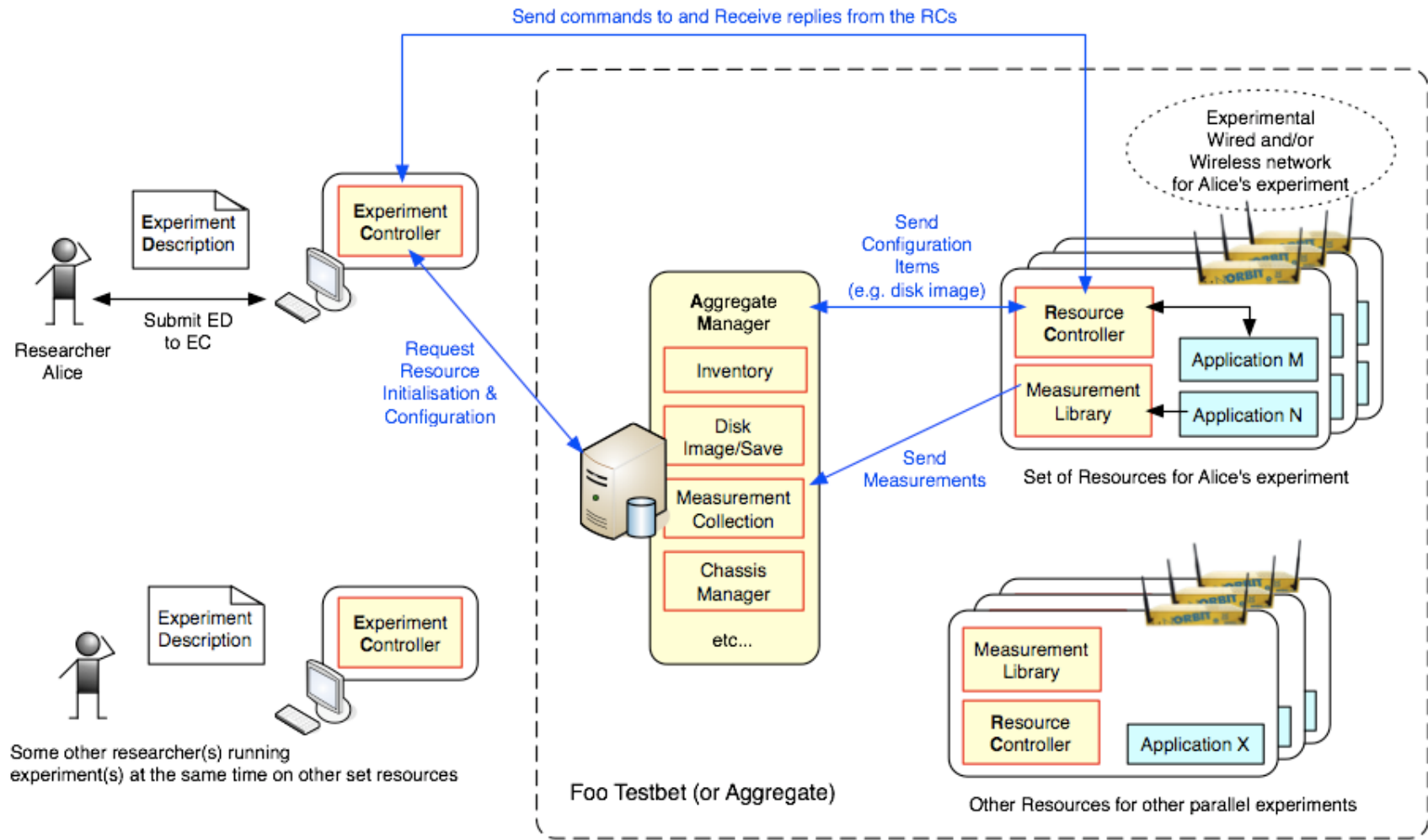

Handling Measurements - OML

- OML stands for **OMF Measurement Library**
- It is a companion software framework for OMF, focused on supporting the lifecycle of measurement data, i.e.:
 - Generation and capturing
 - Processing – Filtering
 - Collection
 - Storage
- It can also be used independently of OMF, in any environment where devices connected to a network generate measurements

Handling Measurements - OML

- OML server:** responsible of gathering the measurements and storing them in a database
- OML client:** software library for injecting measurements generated at measurement points (MP) inside applications into streams towards the OML server

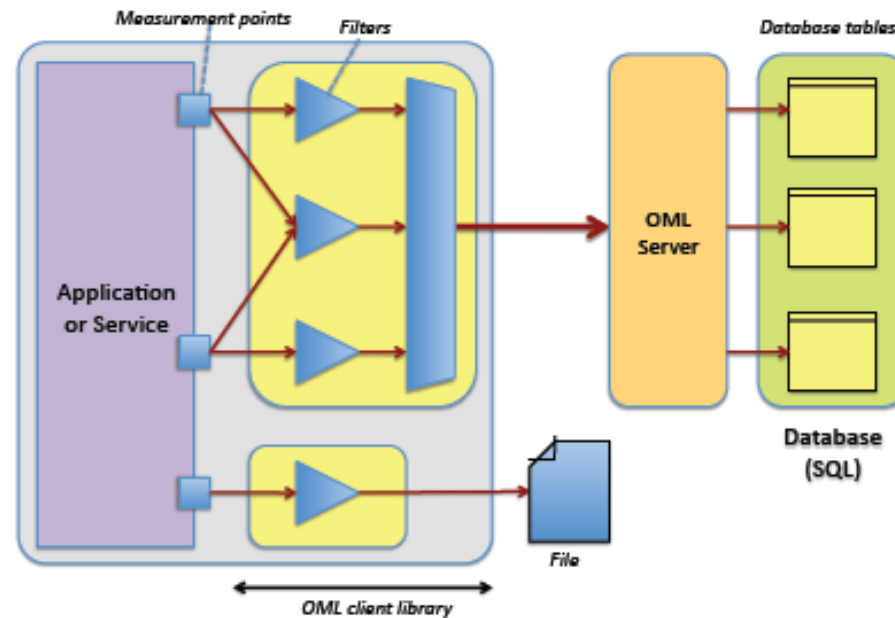

OML Architecture

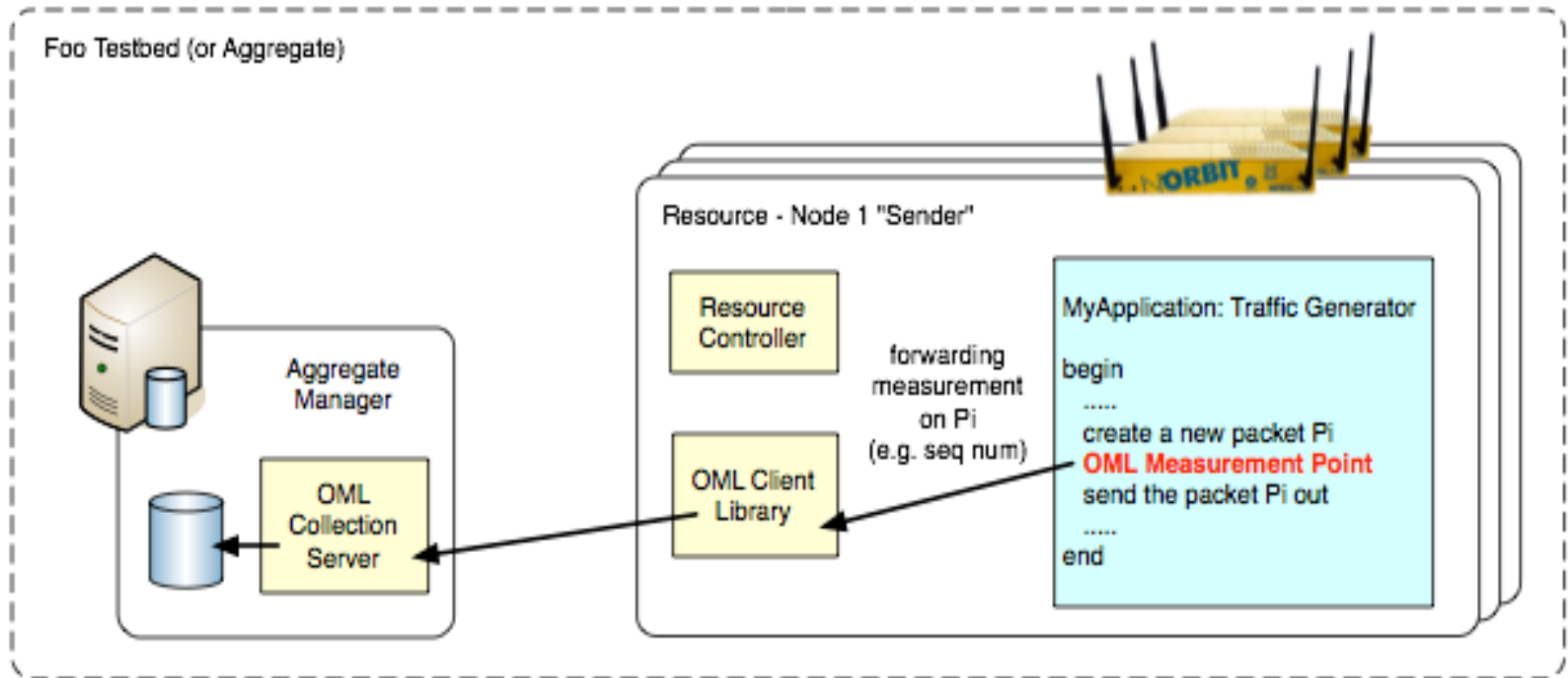

Measurement Points

- Measurement points can be defined as the stages at which the measurements are to be collected.
- They are **C structures**, in which a set of measurements is defined as a standard variable data type (e.g. long, double).
- You can define **custom measurement points** within the source code of the applications that are part of the experiment.

Experiment Lifecycle

All the procedures described fit together to create the experiment lifecycle in an OMF-testbed:

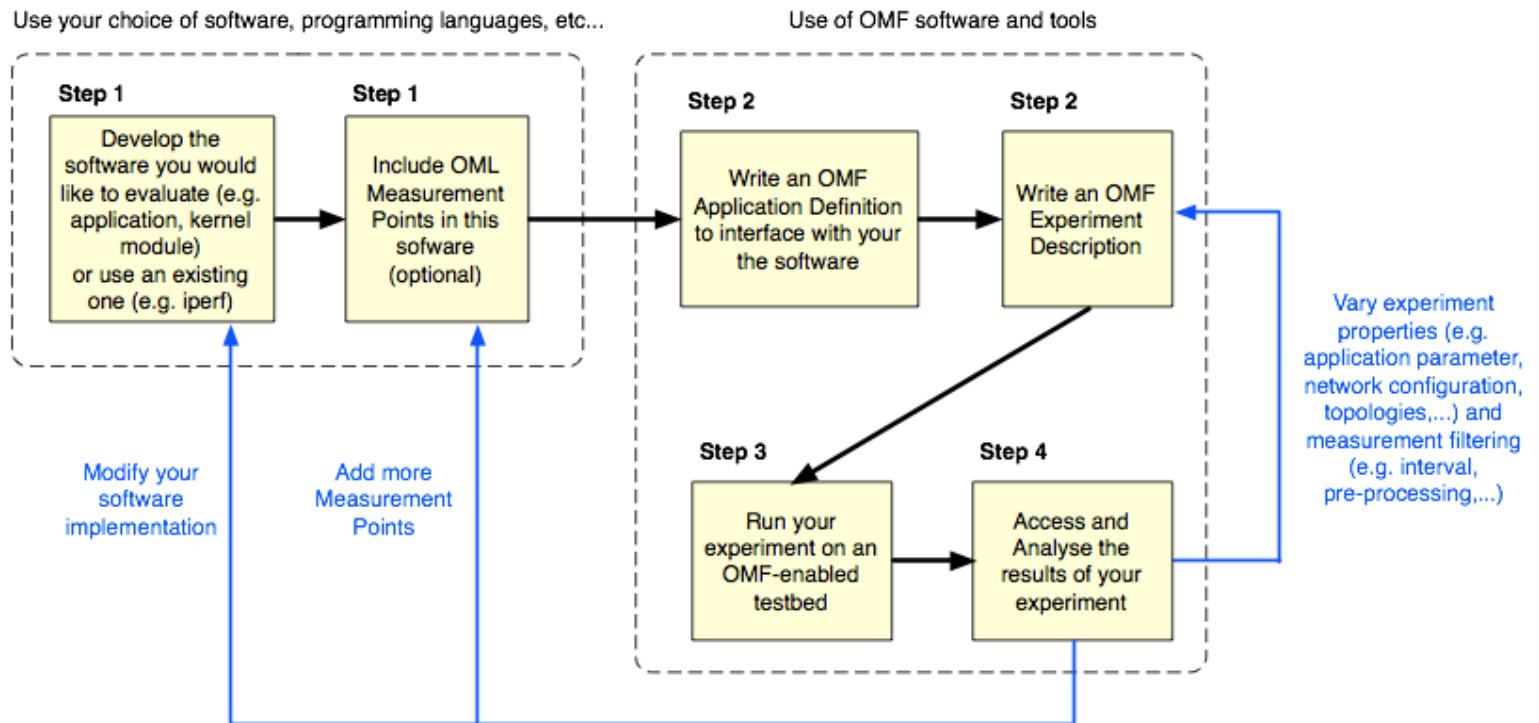

Some extra features: OMF graph visualization tool

- A graphical visualization tool allows for real-time monitoring of the measurements collected by the OML server as part of an experiment
- This feature has been available as part of OMF EC's web interface. It will soon evolve as a standalone visualization feature of OMF

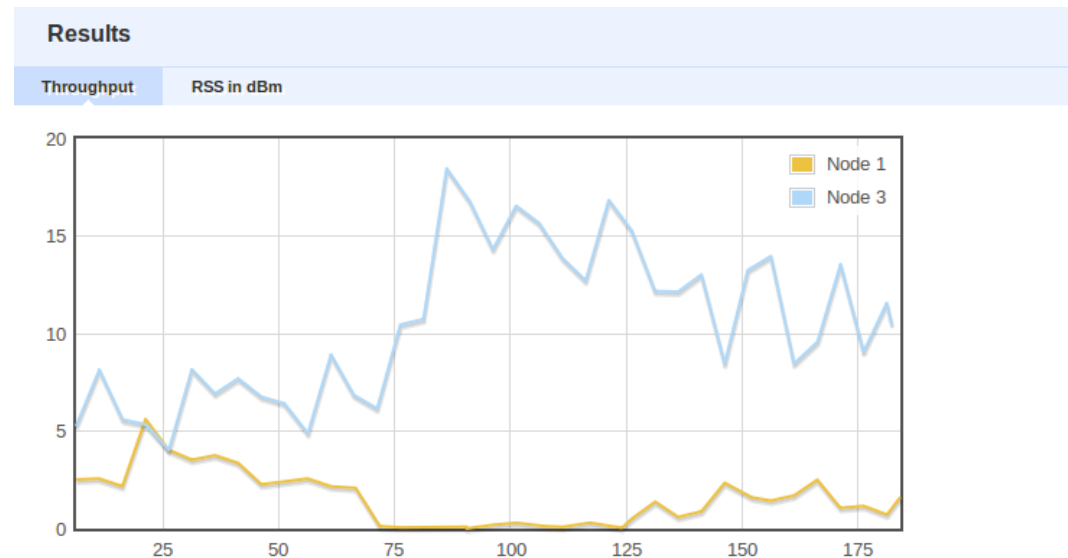

This graph shows the Throughput from the UDP traffic.

Some extra features: support for disconnected experiments

- In experiments involving mobility, some resources may move out of the range of the control and measurement collection network for a fraction of the experiment duration
- In order to support seamless collection of measurements from these resources, a **proxy server** is available as part of the OML client software. In case of disconnection, measurements are buffered in it locally, until the resource returns within the control network's range

Disconnected experiment: An example

- NITOS features a vehicular based setup, where cars carry wireless nodes with environmental sensors
- Multiple Road Side Units (RSU) are installed in several places of Volos
- When a car gets in the range of an RSU, forwards its measurements to the system

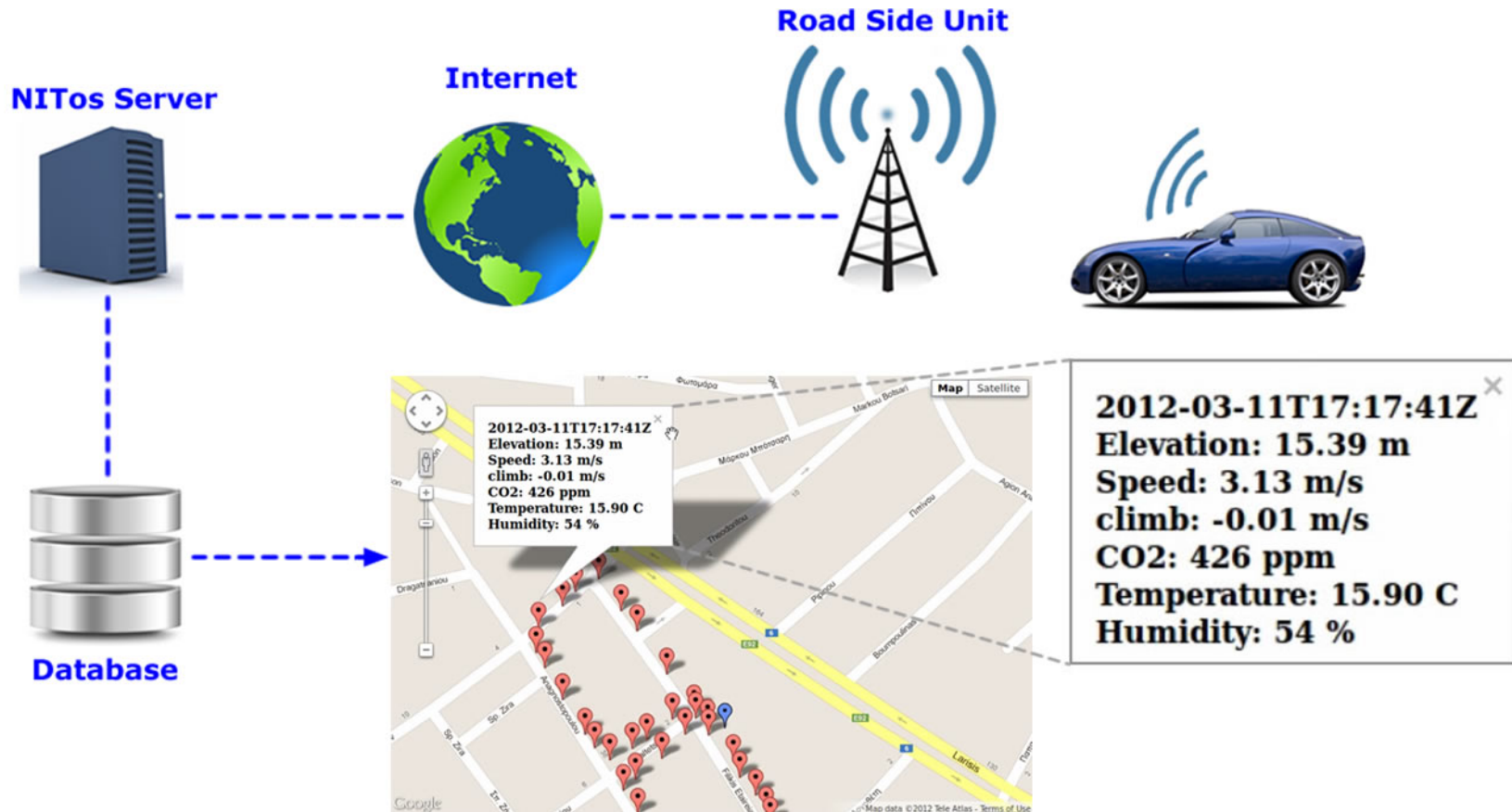

NITOS Connectivity Tool

- NITOS has developed a connectivity tool which provides information about link quality among nodes
- The data is available on the NITOS website and is updated frequently.

Topology-Connectivity

This is the topology of our testbed residing on the building of Computers and Communications Engineering Department of University of Thessaly in Volos.

Choose Node, Channel and Rate to view the Node's connectivity

Please choose sender Node

Node 01

Please choose Frequency

IEEE802.11b/g : Channel 1 : 2412MHz

Please choose Rate

6 Mbps

Show connectivity

Blue dots represent Diskless Nodes
Yellow dots represent Orbit Nodes

NITOS Connectivity Tool

Receiver's MAC address

PDR metric

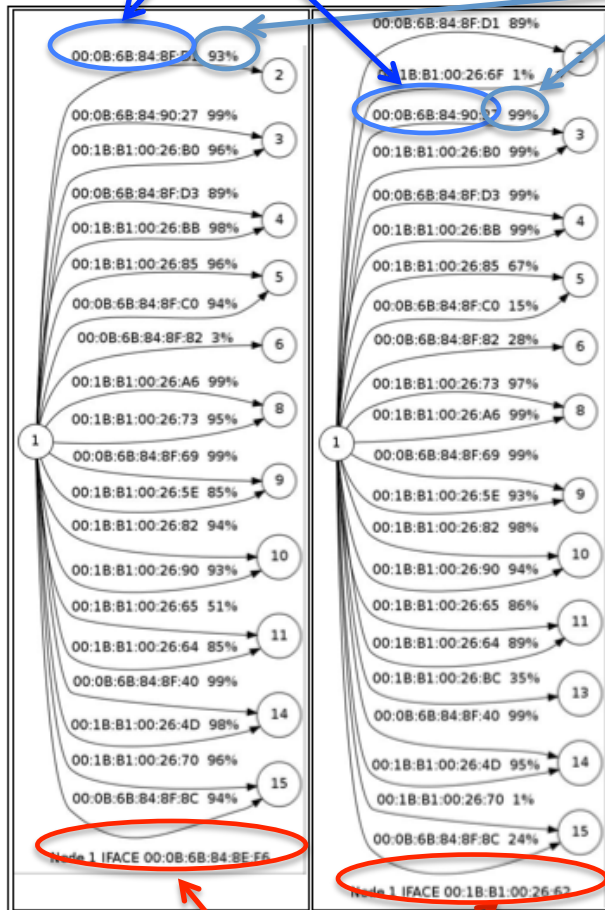

- Figure illustrates the connectivity of both wireless interfaces of a node with all the other NITOS testbed nodes, based on **PDR** metric

Sender's MAC address

RF Sensing through SDR

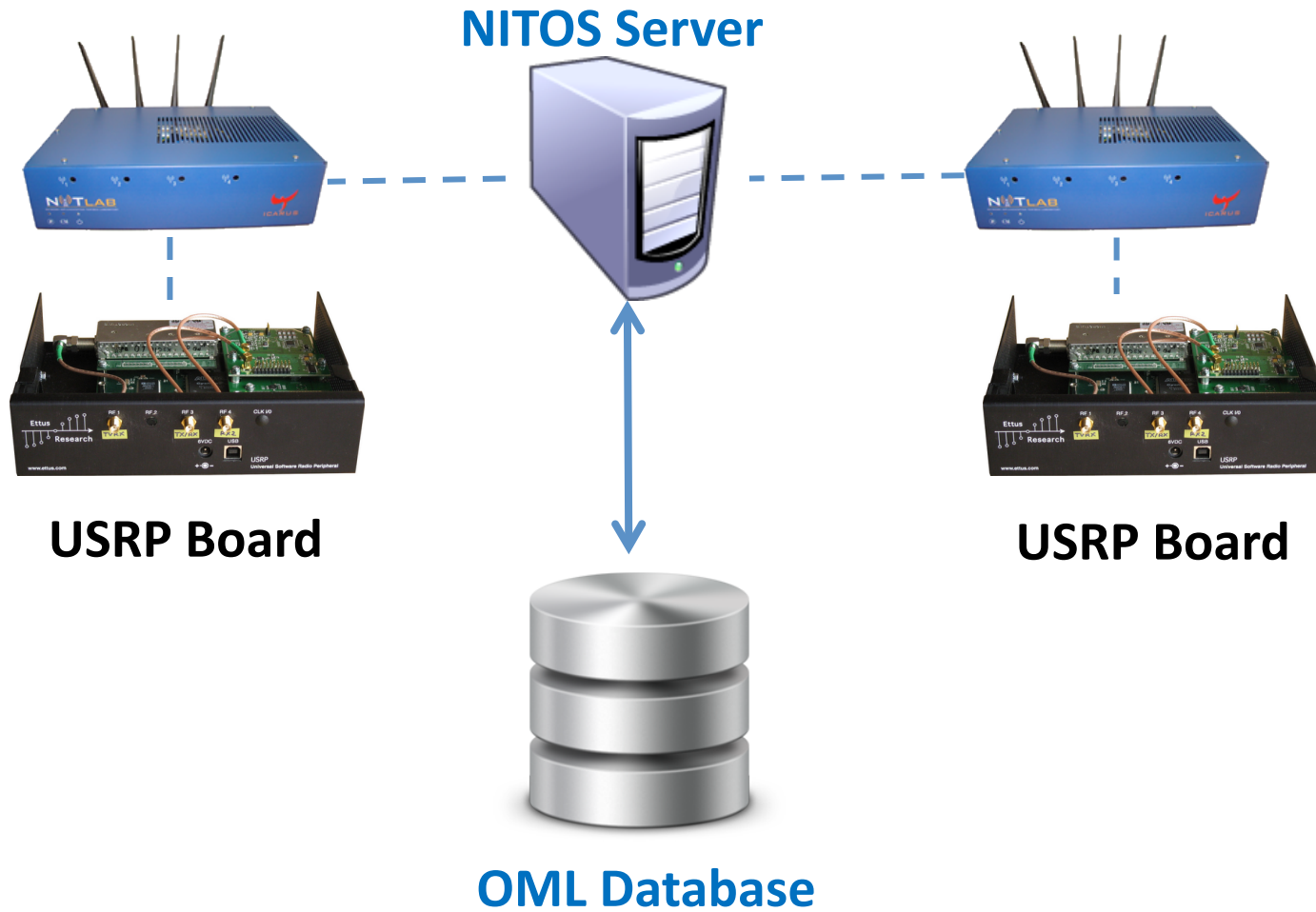

RF Sensing through SDR

- Exploiting USRP boards, NITOS provides real time RF sensing in order to feed back the experiment, regarding the transmitted or not frames.

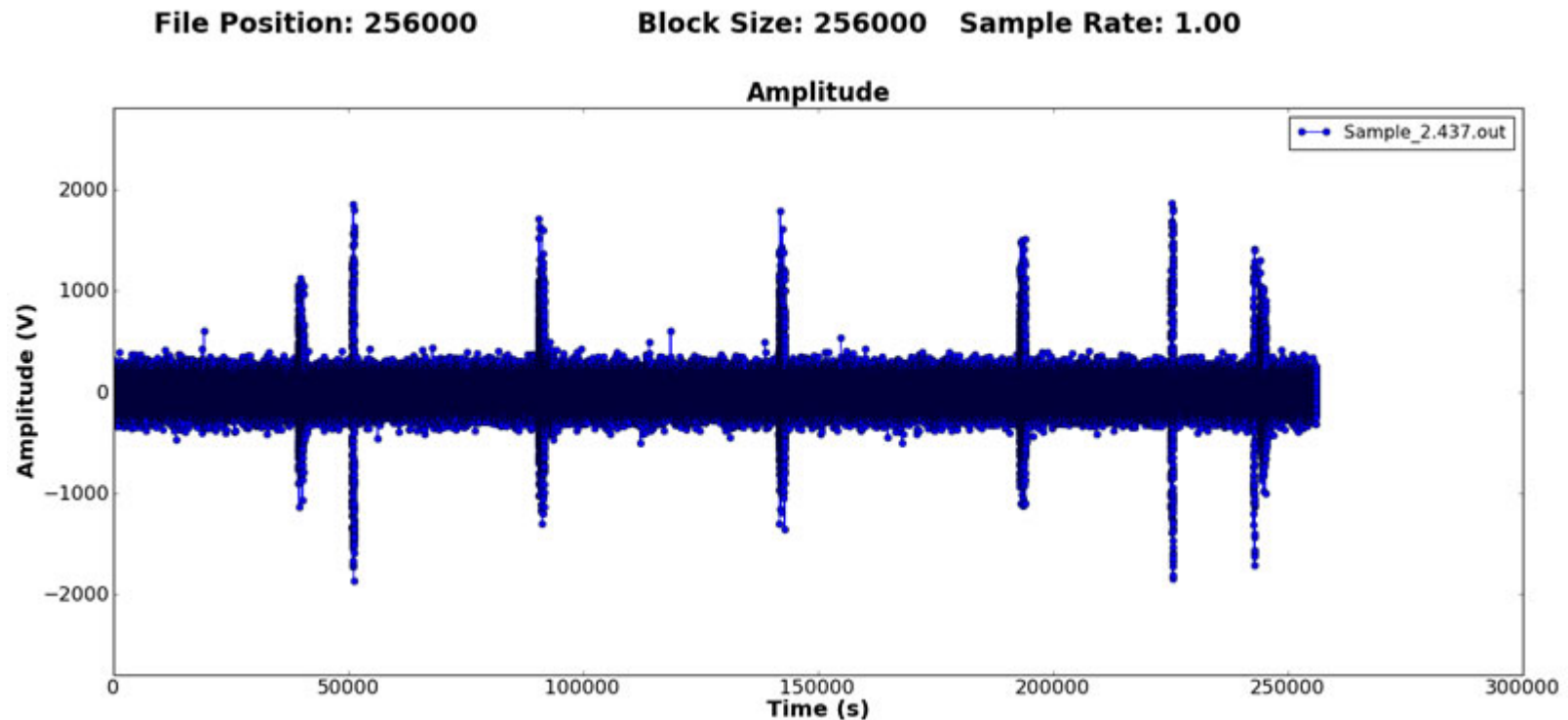

NITLab sensors Framework

NITOS provides its users with the ability to run experiments using the temperature, humidity and light sensors (online) or even access **real sensor records** by using the **NITOS Sensors Toolkit** (offline) through **OMF Framework**

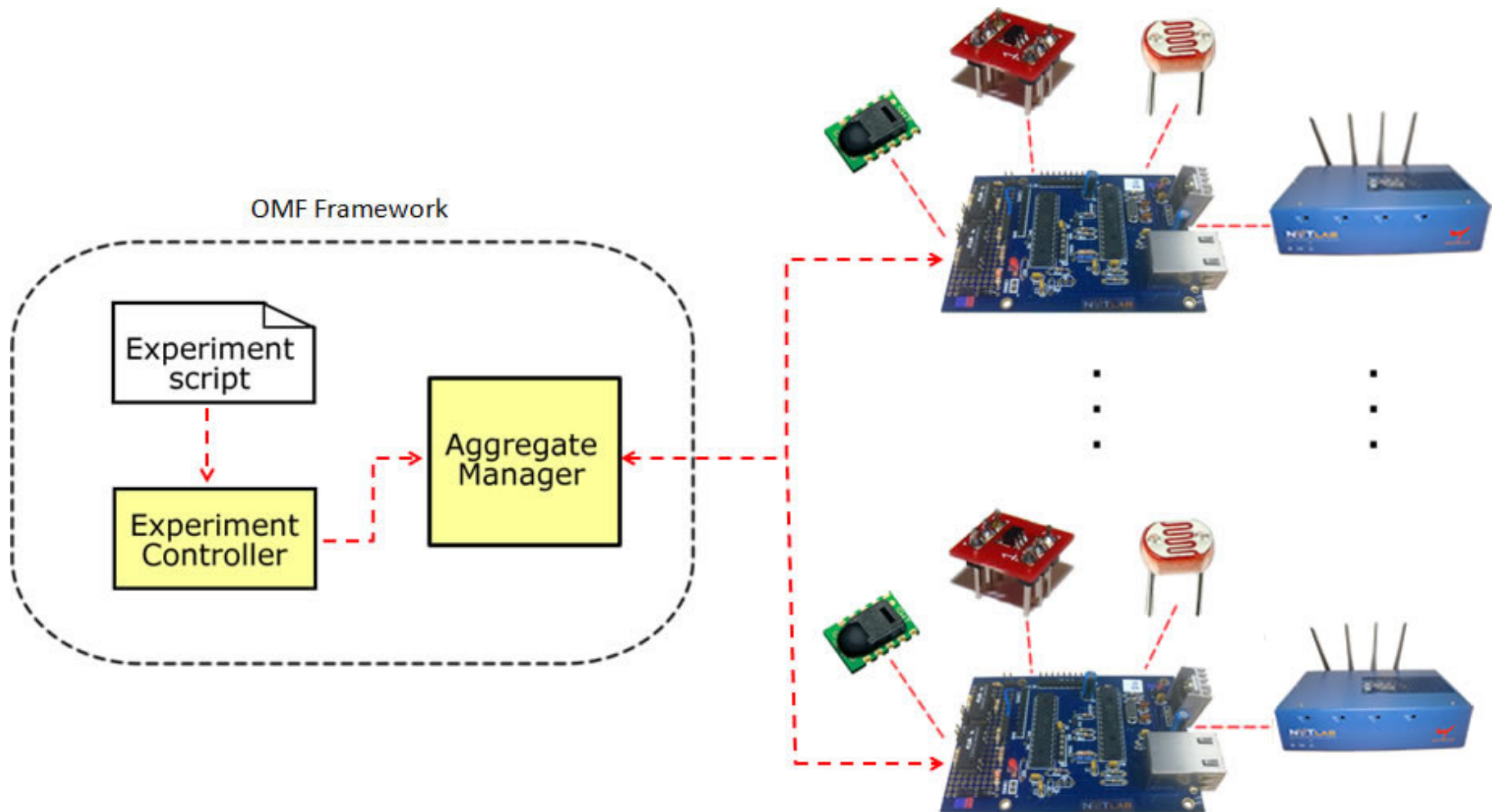

Experimentation in Cooperative Networks

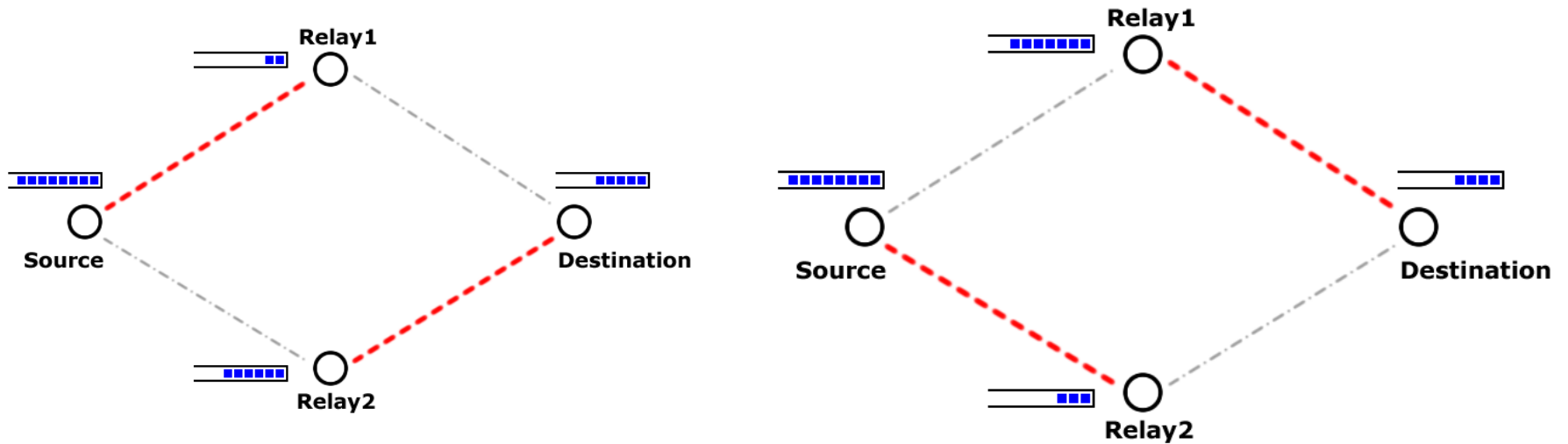

- **Cooperation:** Exploit different paths through the aid of possible relays that carry out the traffic
- Aim is to boost networking performance.
 - Increase Throughput
 - Minimize Power Expenditure

Measurements on Experimentation with Cooperative Networks

- Measurements in the cooperative networks implementation:
 - Before we use the testbed we use the NITOS connectivity tool to define the topology of the experiment based on channel conditions.
 - Using OMF/OML we define multiple measurement points in each station measuring:
 - Overall Throughput
 - Packet delay
 - Jitter
 - During the experiment, we observe the experiment's environment through sensing with USRP2s (controlling the sensing with OML)

THANK YOU!